

### Key Features

- Gives secure locking and controlled ventilation in one simple operation.
- Ideal for use in schools, hospitals, offices, hotels, residential homes, and sheltered housing.
- Can be fitted to most timber, pvc-u, aluminium, steel and composite windows.

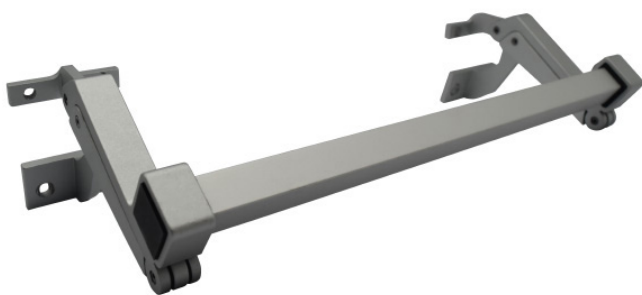

### Index

### Page

Introduction	2
Fixing Details	2
Key Features	3
Model Options	3
Applications Data	4
Accessories	5-6
Operation Of High Level Openers	7
Link Arms	8
Anchor Insert Application Details	9
Folding Opener Quick Reference Matrix	10-11
Opener Availability	11
Applicable Standards	11
Testing	11
Warranty Details	11
Maintenance	11
Trouble Shooting Guide	11
Order Form	12

All of the information shown on this data sheet was taken from the Caldwell Fabricators Manual 27th Edition and correct at the time of issue. All information however is subject to change and therefore it is advisable to check with Window Ware to ensure that you have the latest issue level.

Caldwell's range of folding openers are the premier "over centre cam stay" in the uk.

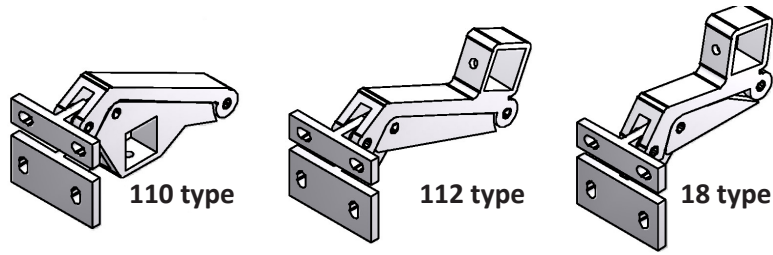

Folding openers can be used to positively lock a window into a closed or open position with a specific, restricted gap. They are gravity dependant and therefore best suited to top-hung windows, although they may also be fitted to bottom-hung, fully reversible and pivot windows. The wide range of fixing brackets available on folding openers mean they are suitable for use on aluminium PVC-U, timber, steel and composite windows.

## Fixing Details

### PVC-U Windows

When using PVC-U windows, always fix into reinforcement.

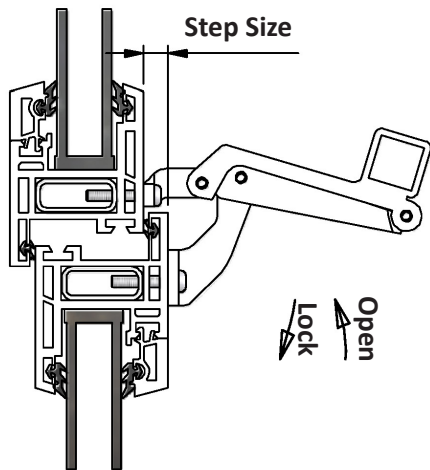

### Timber Windows

When using timber windows, do not fit too close to edges of profile. Doing so may cause the timber to split. (1" min. length screws must be used).

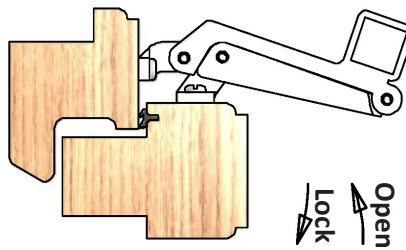

### Aluminium Windows

When using aluminium windows, only use recommended fixings. (Check with systems company if in doubt).

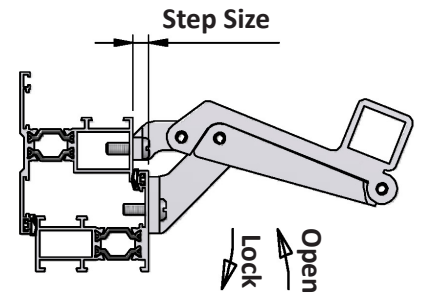

When fixing folding openers to windows the hole centres should be correct to the specification of opener being used. The sash bracket & frame bracket should be in line & square. When fitting tandem bars the folding openers should be square & in line with each other.

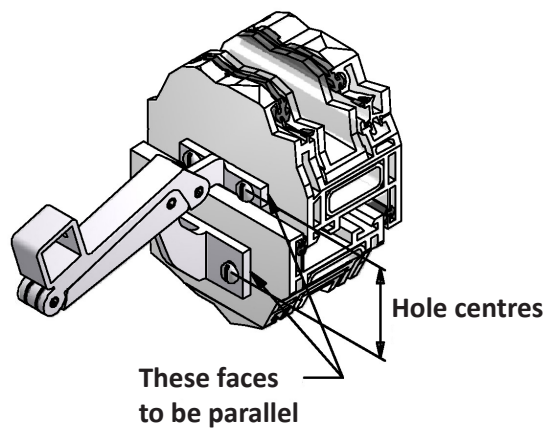

When a sash is hung on butt hinges the minimum sash height should be no less than 250mm.

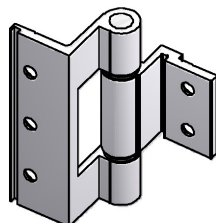

If the sash is hung on friction stay hinges then the minimum sash height is 400mm.

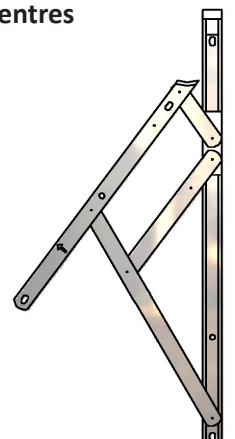

Step size is very important when specifying folding openers.

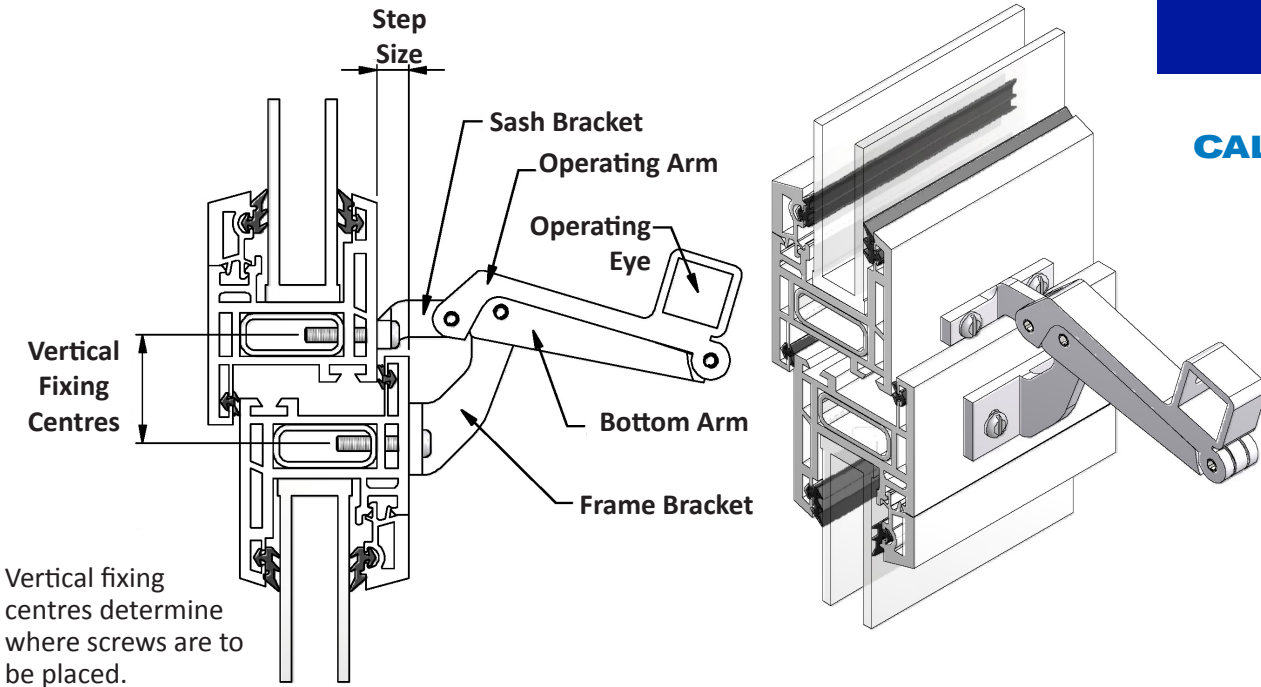

## Model Options & Finish Options

The simplicity of use and robustness of folding openers make them particularly suitable for schools, hospitals, offices, care homes and sheltered housing.

Folding openers can be linked in twos or threes to accommodate different window widths and certain types can be operated at high level by using a tandem eye and pole operator.

The two standard types of folding opener give a sash movement of 150mm (112 & 110 types). If a smaller opening is required then a shorter folding opener is available. The 18 type folding openers give a sash movement of 100mm.

Sash Movement	Folding Opener
100mm	18 Type
150mm	110 & 112 Type

All folding openers are available in locking and/or releasable form and range are also available in fold aside form

The standard finish for all folding openers and accessories is silver anodised (AA15).

## 110 Type

The action of the 110 type folding opener allows the operating eye to remain inside the building even when the window is fully open. This is therefore ideal where pole operation is required. Hand operation of these folding openers is not recommended especially when linked. The geometry of these folding openers means there is a chance that fingers could become trapped. When using a 110 type on a hopper (bottom-hung) window a minimum of 85mm must be left above the top arm of the folding opener. This allows the folding opener to snap up.

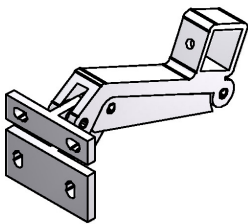
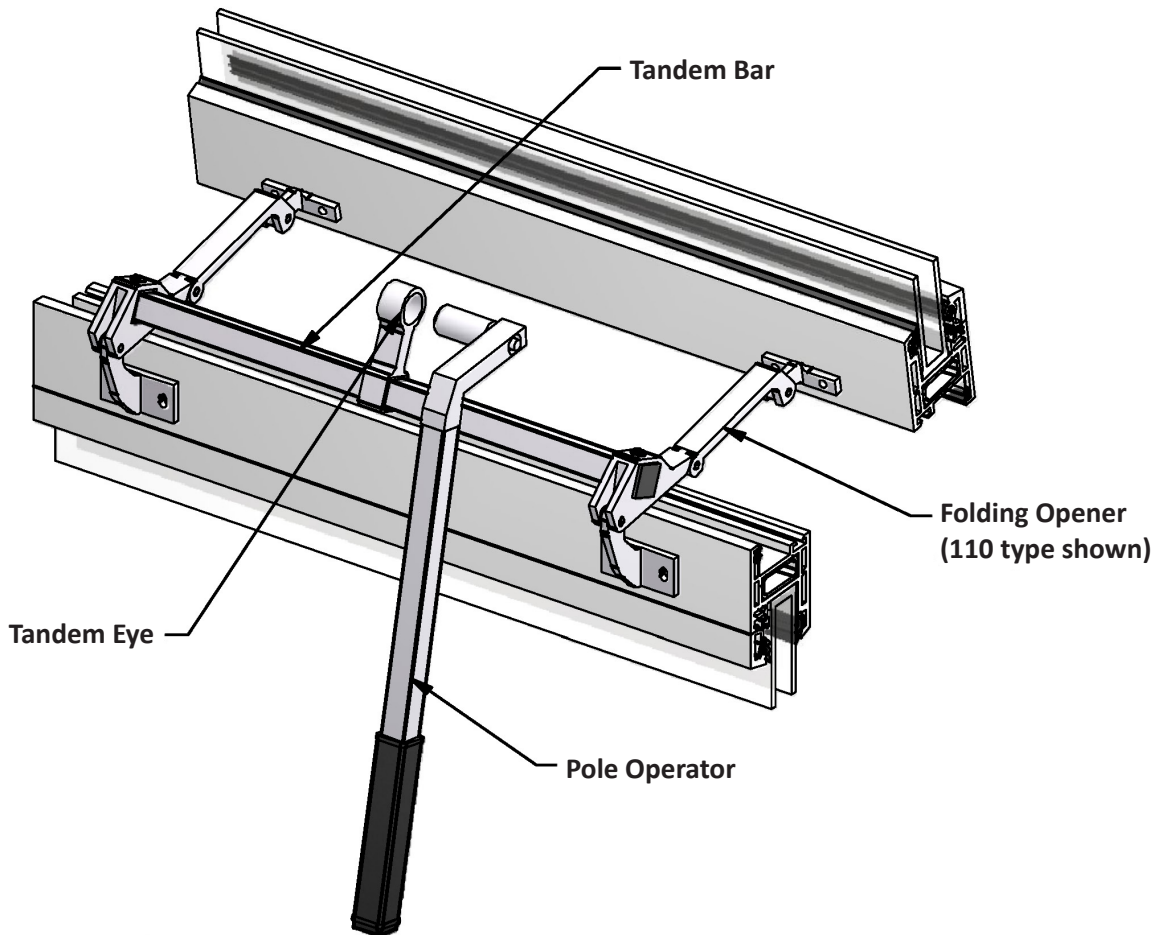
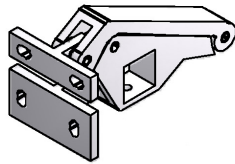

## 112 Type

The action of the 112 type folding opener ensures that the operating eye and tandem bar do not interfere with internal cill boards. The position of its operating eye gives an extended arc of operation making it ideal for hand operation.

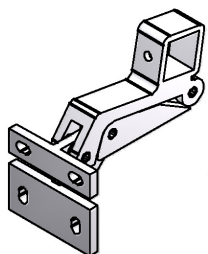

## 18 Type

The 18 type folding opener is similar to the 112 type folding opener however its operating arc is smaller.

## Tandem Bar Rules

1	Folding openers must be positioned between 00mm and 200mm from the corner of the sash. The tandem bar therefore should be 200mm to 400mm less than the width of the window.
2	Tandem bar lengths are always specified by hole centres and not overall length.
3	The maximum distance between linked folding openers should not exceed 900mm. If a 1000mm length tandem bar is required then a third folding opener must be used.
4	If possible the length of tandem bars should be rounded up or down to the nearest 50mm increment (i.e. 550,600....850....etc.)
5	When a third folding opener is used, a tandem bar with a centre hole can be supplied. A modified end cap 25064/M is also required.
5	If a fourth folding opener is required a tandem bar will be supplied with no centre holes for the inner two folding openers. Two modified end caps 25064/M will be needed.

## Tandem Bars

Tandem bars range in length from 200mm to 4000mm depending on the width of window. When using tandem bars it is important to follow the tandem bar rule rules shown opposite.

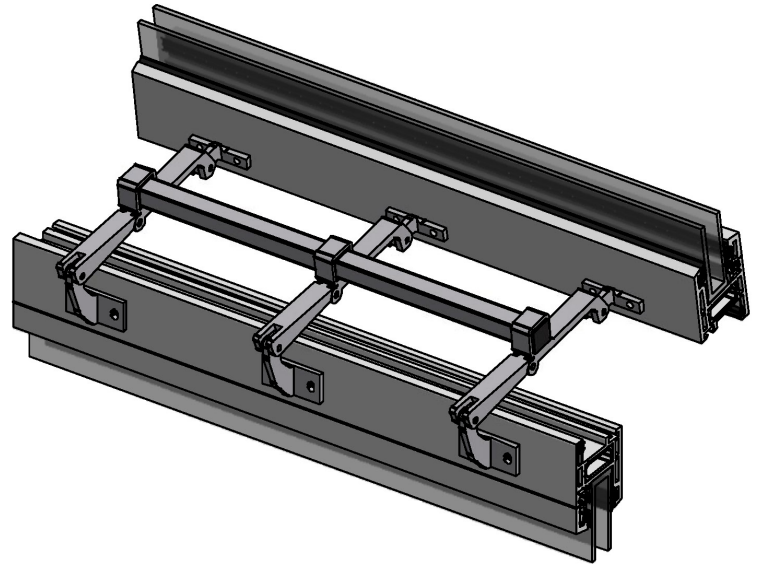

## Tandem Bar Lengths & Number of Openers Required

Formulae for tandem bar lengths:  $x = \text{Sash width} - 300$  (round up or down to the nearest 100mm).

x = 0mm to 400mm	x = 401mm to 900mm	x = 901mm to 1800mm	x = 1801mm to 2700mm	x = 2701mm plus
1 opener *	2 openers	3 openers	4 openers	Contact Technical

\* The number of folding openers shown above is the minimum number that Caldwell recommends to achieve satisfactory open & close functions in domestic/low usage applications. On high use applications, such as schools, hospitals & public buildings where there will be multiple users, then Caldwell always recommends the use of at least two folding openers as long as space permits. Generally this will offer a more robust operation compared to that of a single folding opener.

## Pole Operators

The standard length of pole operators is 1400mm. Longer or shorter pole operators are available on request. The length of pole operators is rounded up or down to the nearest 100mm increment. Pole operators are supplied with either a large or small boss depending on the style of tandem eye being used (small boss required for single folding openers).

Part No.	Description
CFO14000S	small boss (Ø18mm) with 1400mm long pole operator

## Hand Operator

The hand operator comes in one standard size and will fit any folding opener (where no tandem bar is fitted). The Caldwell part number is PE164.

## Tandem Eye Adaptor Kit

Caldwell's PE196 tandem eye adaptor is for use where a 263 tandem eye is required on a single folding opener. The kit includes the tandem eye, adaptor bar, end cap, & screw fixings.

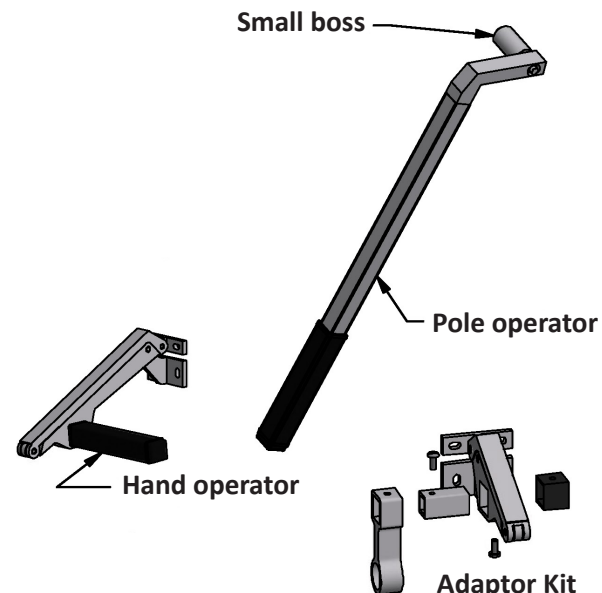

## Tandem Eyes

Pole operation of a single folding opener does not normally require a tandem eye. Tandem eyes are necessary when pole operation is needed to work two or more folding openers which are linked by a tandem bar. The tandem eye should be fitted either centrally (in the case of two folding openers) or immediately to the side of the central folding opener (in the case of three folding openers). Two types of tandem eyes are available and the recommended fitting positions are shown below. Tandem eye kits include two end caps & three self tapping screws. Any alternatives to the fitting positions shown below should be fully tested before installation.

### 262 Tandem Eye

The 262 tandem eye is especially suited to the 112 type folding openers where an extended operating arc is required. Whilst the 112 type folding openers are not ideal for pole operation, there may be applications where a tandem eye is required i.e just out of reach. If pole operation of a 112 type folding opener is planned, then testing must take place prior to installation. The 262 tandem eye should be operated with a pole operator.

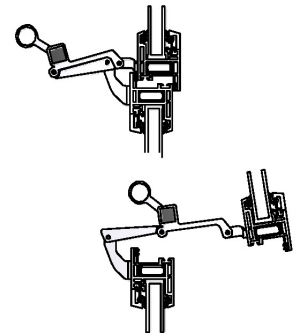
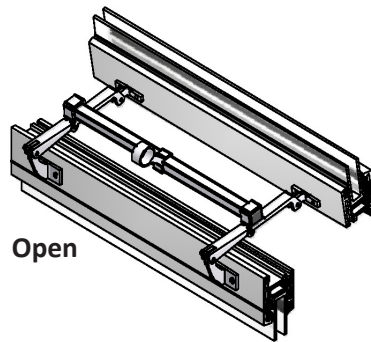
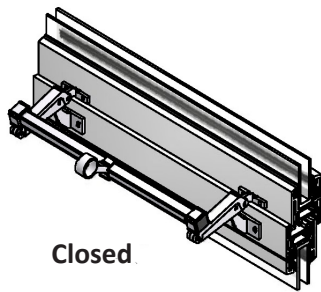

### 263 Tandem Eye

The 263 tandem eye is generally used on the 110 type folding openers to give an extended operating arc. It should be operated with a small boss pole operator. If this folding opener is to be used at high level with a cill board, make sure adequate clearance is taken into account.

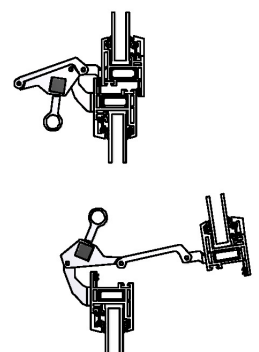
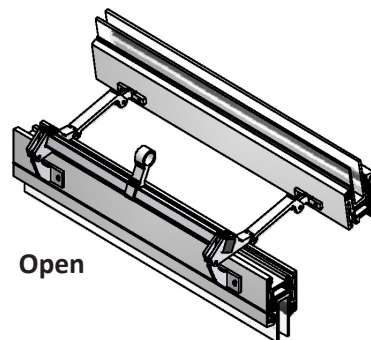
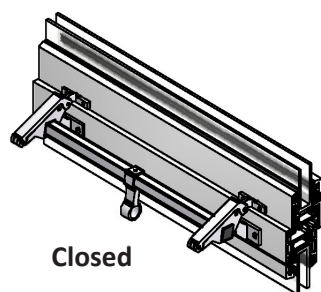

## Packers

Vent bracket packers are available to accommodate intermediate step sizes. 4 sizes are available 1.0mm (CFO90001), 2.0mm (CFO90002), 3.0mm (CFO90003) & 5.0mm (CFO90005), 1.00mm, 2.0mm & 3.0mm are aluminium and the 5.0mm is moulded black nylon. Frame bracket packers are also available in a 5.0mm (CFO91005) step in aluminium on request.



# Caldwell Folding Opener

Operation Of High Level Folding Openers

**5**  
YEAR GUARANTEE

**WINDOW  
WARE**

*We've got it*

When using high level operation please ensure the correct standing position.

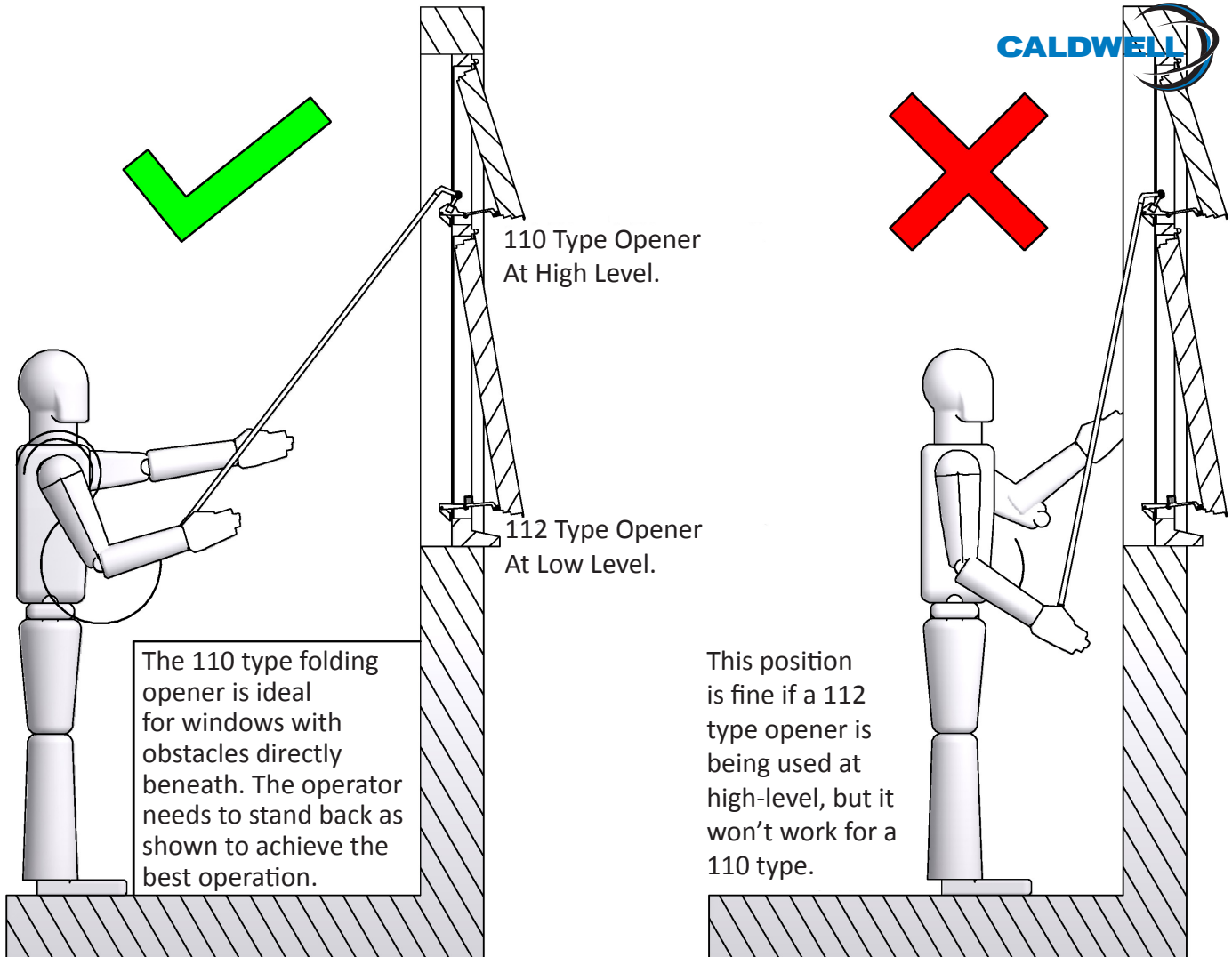

## 110 Type

folding opener is designed for high level use. Due to the design of this opener, it is much easier to operate with a pole operator.

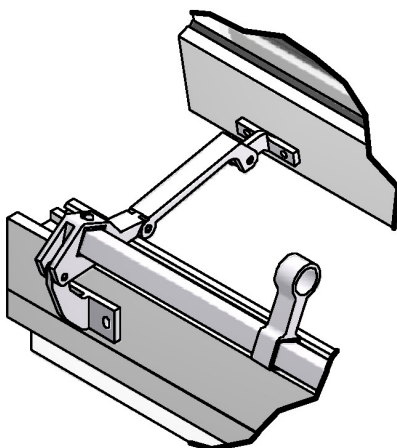

## 112 Type

folding opener is designed for low level hand operation (same as 18 type & extended). Caldwell always recommend the 110 type folding opener for use at high level. If a 110 type folding opener can not be used then a trial fit of 112 type must take place to establish suitability in situ. If a 112 type opener has to be used the operator must stand close to the window & move the opener in an arc motion.

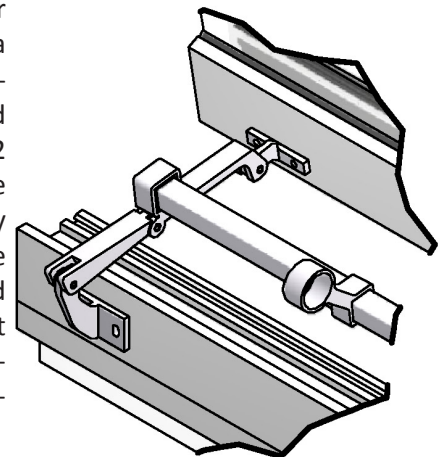

**Notes:**

Different step sizes are available depending on quantities.

Link Arm Folding openers are available in locking and releasable or in a combination of both.

For further informaton please contact technical support on 01234 242738.



117L023, 190L023, 130L023, 112L023,  
130L044, 190L026

DIM A	FO TYPE	DIM B	Caldwell Code
45mm	112	23mm	130L023

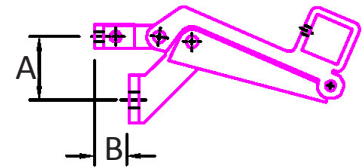

### Important Application Notes

- If possible, applications requiring link arm folding openers should be trial fitted on a window before ordering in bulk.
- Care must be taken to ensure that the rear of the link arm does not clash on the cill especially when moving to the open position (please refer to DIM Y).
- The length of the link arm and the window height will determine the size of the DIM X required.
- For further information please contact technical support on 01234 242738.

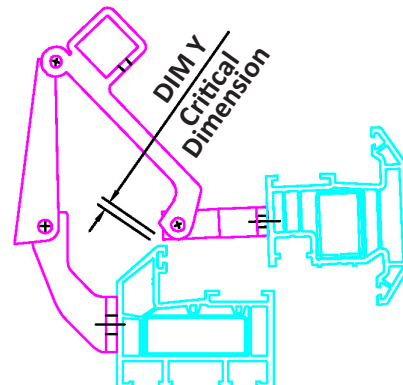
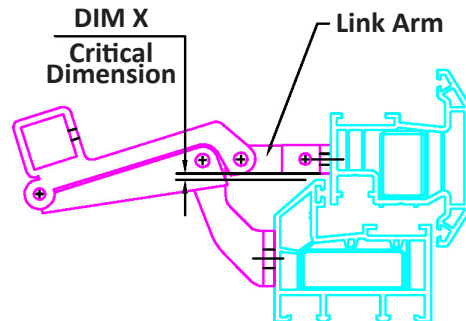
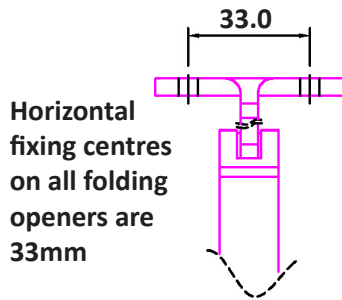



# Caldwell Folding Opener

Rivet nut insertion for aluminium windows

**5**  
YEAR GUARANTEE

**WINDOW  
WARE**

*We've got it*



Thread Size	Hole size	Material Thickness	DIM X
M4	Ø 6.0mm & Counter Sink Ø 7.0mm at 90°	0.25-3.0mm	12.0mm
M5	Ø 7.0mm & Counter Sink Ø 8.0mm at 90°	0.25-3.0mm	12.5mm
M6	Ø 9.0mm & Counter Sink Ø 10.0mm at 90°	0.25-3.5mm	15.5mm

## STEP 1

Drill fixing holes

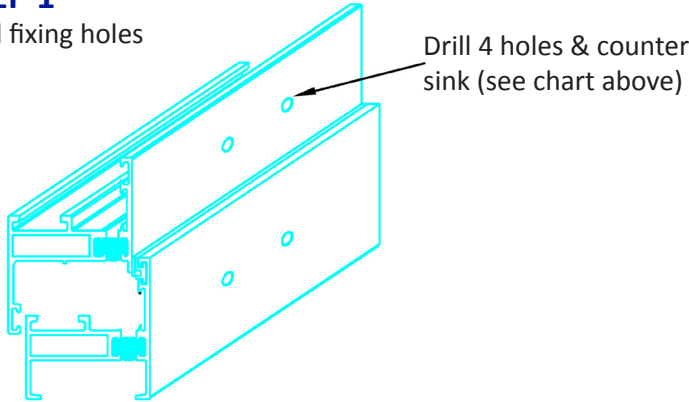

## STEP 2

Screw insert onto gun

Set stop on gun to prevent over compression of insert

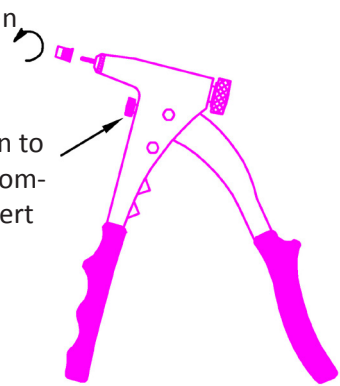

## STEP 3

Compress insert

Push rivet nut insert into hole and squeeze the gun handles together (Do not over compress)

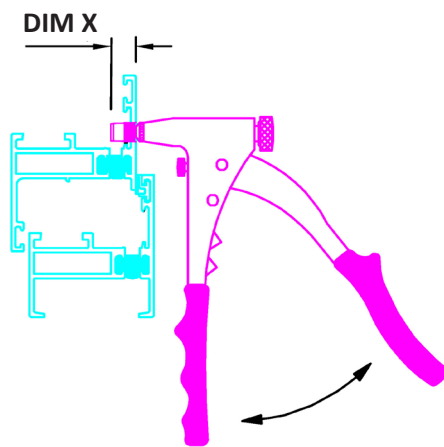

## STEP 4

Release gun from insert

To release gun from insert unscrew the handle until released from the insert

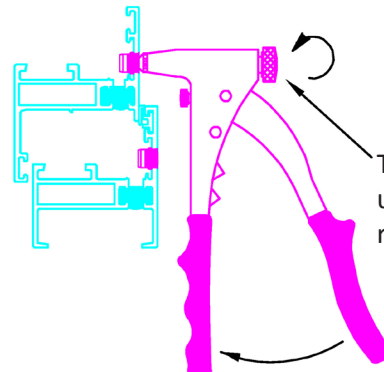

## STEP 5

Fix folding opener

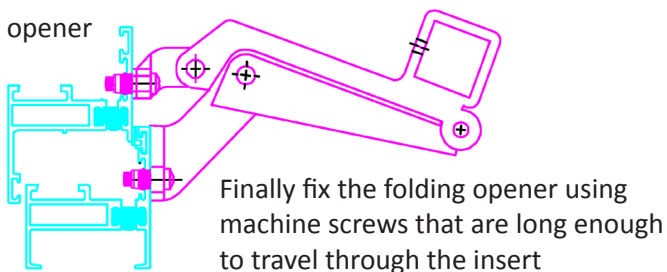

The inserts have been tested and approved by Caldwell Hardware for particular applications, they are shown as a suggestion only. A copy of (test report GTR-0029) is available on request.

Screws must be DIM X + component thickness minimum.

Folding openers are available in locking, releasable and/or fold aside form. Link arm folding openers are available for some step sizes over 16mm. For further information please refer to catalogue or contact the technical support department.

For diagrams please see page 11

FO TYPE	DIM A (Vertical Screw Fixings)	Plate Height		DIM B (Step)				
		Frame Fix	Sash Fix	Flush	5mm	7mm	11mm	16mm
111	25mm	25mm	10mm	-	-	CFO11107	CFO11107 + 2 x 2mm Packers CFO90002	CFO11116
112	25mm	25mm	10mm	CFO11200	CFO11205	CFO11207	CFO11207 + 2 x 2mm Packers CFO90002	CFO11216
113	15mm	17mm	9mm	-	-	CFO11307	CFO11307 + 2 x 2mm Packers CFO90002	-
117	35mm			CFO11700	-	-	-	-
117	32mm	25mm	10mm	-	CFO11700 + 5mm Packer CFO90005	CFO11707	CFO11707 + 2x2mm Packer CFO90002	CFO11716
130	45mm			CFO13005 + 5mm Frame Packer CFO91005	-	-	-	-
130	38mm			-	CFO13005	CFO13007	CFO13016 + 5mm Frame Packer CFO91005 or CFO13007 + 2 x 2mm Packers CFO90002	CFO13016
131	38mm	25mm	10mm	-	-	-	CFO13116 + 5mm Frame Packer CFO91005	CFO13116
180	25mm			CFO18005 + 5mm Frame Packer CFO91005	CFO18005	CFO18005 + 2mm Packer CFO90002	CFO18005 + 5mm Packer CFO90005 & 1mm Packer	-
183	32mm	25mm	10mm	-	CFO18305	CFO18305 + 2mm Packer CFO90002	CFO18305 + 5mm Packer CFO90005 & 1mm Packer	-
187	48mm	25mm	10mm	-	-	-	CFO18716 + 5mm Frame Packer CFO91005	CFO18716
190	53mm			CFO19005 + 5mm Frame Packer CFO91005	-	-	-	-
190	48mm	25mm	10mm	-	CFO19005	CFO19005 + 2mm Packer CFO90002	CFO19016 + 5mm Frame packer CFO91005 or CFO19005 + 5mm Packer CFO90005 & 1mm Packer	CFO19016
191	48mm	25mm	10mm	-	-	-	CFO19116 + 5mm Frame Packer CFO91005	CFO19116
FO TYPE	DIM A (Vertical Screw Fixings)	Plate Height Frame Fix	Sash Fix	DIM B (Step)				
				19mm	24mm	26mm	30mm	35mm
118	25mm			CFO11826	-	-	-	-

## AVAILABILITY

Standard folding opener products in clear anodised finish are usually available on a lead-time of 5-7 working days.

## APPLICABLE STANDARDS

Caldwell Manufacturing operates a **BS EN ISO 9001:2008** accredited quality assurance system and all products supplied are controlled through the manufacturing processes by this system.

The aluminium extrusions used for the key components are produced in accordance with **BS EN 755-9:2008**.

The anodic coatings on the components are all carried out in accordance with **BS EN ISO 7599:2010** and will meet the requirements of **BS7412:2007** for corrosion protection levels.

## TESTING

Each folding opener is tested for function prior to dispatch. Folding Openers have been cycle tested in excess of 100,000 cycles without defect.

## WARRANTY DETAILS

All Caldwell Hardware folding opener products are warranted free from defects of materials and workmanship for a period of 5 years from date of supply. For full details of the warranty, please contact our Customer Service team.

## MAINTENANCE

Caldwell Hardware folding opener products are free from routine maintenance and when installed in accordance with the manufacturer's guidelines should continue to perform for many years without problem. Exposure to atmospheres containing abrasive materials and coastal atmospheres will accelerate wear and tear. Regular cleaning with a non-abrasive, pH neutral, cleaning agent is recommended.

## Troubleshooting

PROBLEM	CAUSE	SOLUTION
Sash won't fully close when folding opener is closed.	Wrong brackets for window step size	Check step size and use correct folding opener part numbers
Sash is fully closed but folding opener is not	Wrong brackets for window step size	Check step size and use correct folding opener part numbers
Folding opener won't lock out in open position	Sash movement being restricted	Remove restriction or fit folding opener type with reduced opening characteristics
Folding opener won't lock out in open position	Sash height too small (refer to min dimensions in manual)	Use alternative window hardware
Folding opener fouls on cill board when closing window	Insufficient clearance between folding opener and cill board	Change folding opener to a more suitable type. (contact Window Ware for advice)
Tandem eye not accessible when window is open	Wrong folding opener type or wrong tandem eye type being used	Refer to accessories details in manual and replace with correct parts
Pole operator does not fit tandem eyes	Large boss pole operator being used with small boss tandem eye	Use a small boss pole operator
Folding opener becomes loose after a time in service on a PVCu window	Fixing screws not engaged into reinforcement	Use screws of the correct length
Folding opener hits top of reveal when used on bottom hung sash	Insufficient clearance	Use universal type folding openers and fit to ensure a minimum of 85mm clearance between folding opener and reveal

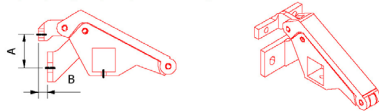

110, 111, 115, 122, 123, 131, & 191

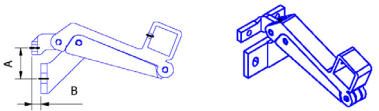

112, 113, 116, 117, 130 & 190



180, 181, 183, 185 & 187

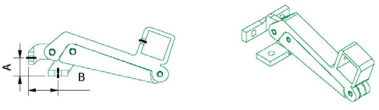

114 & 118

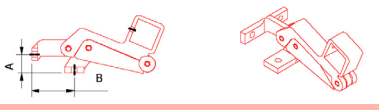

182 & 184

# WINDOW WARE

We've got it

# Caldwell Folding Opener

Order Form

# 5

YEAR GUARANTEE



Window Ware  
Telford way, Cross Park,  
Bedford MK  
phone | 01234 242724

Company Name	
Delivery Address	

Contact	
Email	
Tel No.	
Fax No.	
Date	
Required Delivery Date	

Please Tick		Dimensions Please refer to page 10		Width of Window (If the windows is wider than 900mm it will require 3 folding openers)	Part No. if known	Qty. Required
High Level	Low Level	Step DIM B	Vertical Fixings DIM A			

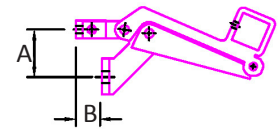

Please Tick				Size/Type	Part No. if known	Qty. Required
Bar	Tandem Eye	Packers	Pole			



262 Tandem Eye



263 Tandem Eye